

Peripheral turbine pumps constructed from cast iron and bronze suitable for domestic uses, hot and cold water boosting and pressure boilers feeding.



SPECIFICATIONS

- Maximum working pressure: 6 bar for PRA 0.50
7,5 bar for PRA 0.80 and 12 bar for the other models
- Maximum liquid temperature:
35°C according EN 60335-2-41 for domestic uses
80°C for other uses

MATERIALS

- Pump body and bracket in cast iron
- Shaft in C10 for PRA 0.50 version
AISI 303 for the other models
- Mechanical seal in carbon/ceramic/NBR

TECHNICAL DATA

- T.E.F.C. 2 poles motor
- Insulation class F
- Protection degree IP44
- 1~230V ± 10% 50Hz, 3~230/400V ±10% 50Hz
- Permanent split capacitor and automatic thermal overload protection for single-phase version
- Thermal protection to be provided by the user for three-phase version
- DNM-DNA 1"

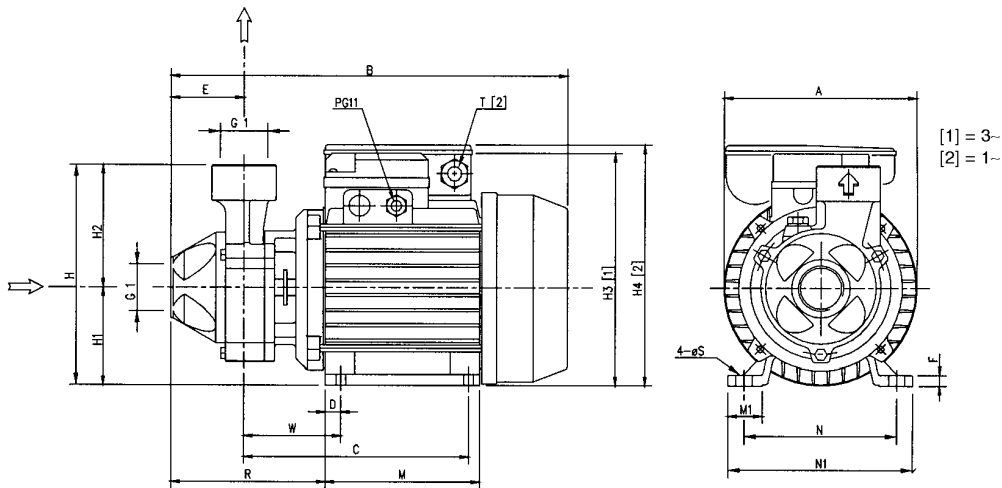

DIMENSIONAL TABLE

Pump type	Dimensions (mm)																			Weight (kg)
	A	B	C	D	E	F	H	H1	H2	H3	H4	M	M1	N	N1	R	T	W	S	
PRA 0.50M	130	263.5	148.5	10	50	7	143	63	80	-	160	100	23	100	120	118.5	PG11	69	7	5.6
PRA 0.50T	130	263.5	148.5	10	50	7	143	63	80	149.5	-	100	23	100	120	118.5	-	69	7	5.6
PRA 0.80M	130	290.5	159.3	11	53.8	9	161	71	90	-	178	112	25	112	135	122	PG11	69	7	9.2
PRA 0.80T	150	290.5	159.3	11	53.8	9	161	71	90	167.5	-	112	25	112	135	122	-	69	7	9.2
PRA 1.00M	150	290.5	159.3	11	53.8	9	161	71	90	-	178	112	25	112	135	122	PG11	69	7	9.7
PRA 1.00T	150	290.5	159.3	11	53.8	9	161	71	90	167.5	-	112	25	112	135	122	-	69	7	9.7
PRA 1.50M	162	330.5	188	12	57	12	175	80	95	-	212	124	28	125	152	144	PG13.5	88	9	14.5
PRA 1.50T	162	330.5	188	12	57	12	175	80	95	186.5	-	124	28	125	152	144	-	88	9	14.5
PRA 2.00M	162	330.5	188	12	57	12	175	80	95	-	212	124	28	125	152	144	PG13.5	88	9	15.8
PRA 2.00T	162	330.5	188	12	57	12	175	80	95	186.5	-	124	28	125	152	144	-	88	9	15.8

PERFORMANCE CURVES (according to ISO 9906 Annex A)

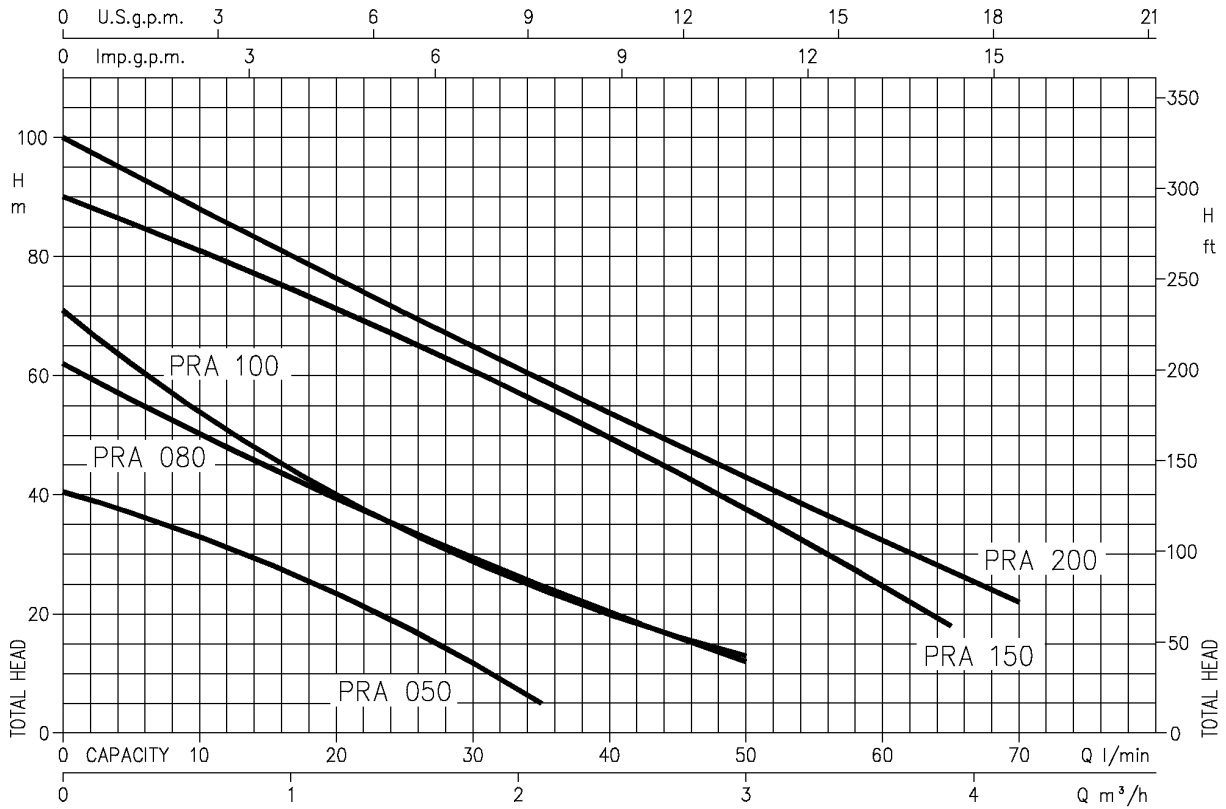

PERFORMANCE TABLE

Pump type		kW	Capacitor		l/min m³/h	Q=Capacity							
Single-phase 230V 50Hz	Three-phase 230/400V 50Hz		µF	Vc		5	10	15	20	35	50	65	70
					H=Total head								
PRA 0.50M	PRA 0.50T	0.37	10	450	37	33.3	28.7	23.7	5	-	-	-	
PRA 0.80M	PRA 0.80T	0.6	16	450	56	50.7	45.1	39.8	25	12	-	-	
PRA 1.00M	PRA 1.00T	0.75	20	450	62	54.4	47	40.4	24.3	13	-	-	
PRA 1.50M	PRA 1.50T	1.1	35	450	-	81	76.9	71.9	55.8	37.9	18	-	
PRA 2.00M	PRA 2.00T	1.5	40	450	-	88	82.9	77	59.8	43.3	27.4	22	