

## CENTRIFUGAL PUMPS - OPEN IMPELLER in AISI 304

Open impeller centrifugal pumps with the hydraulic element manufactured from stainless steel AISI 304, suitable for suspended solids handling food process e.g. washing vegetables, meats, and fish. Industrial washing machines that may contain solids e.g. bottles, jars, glasses & crates. Process applications such as paint plants & general dirty liquid handling. An IP68 submersible is also available.



### SPECIFICATIONS

- Maximum working pressure: 8 bar
- Maximum liquid temperature: 90°C
- Passage of solids: maximum diameter of 19 mm

### MATERIALS

- Pump body, casing cover, impeller and shaft in AISI 304
- Bracket and motor casing in cast iron
- Mechanical seal in carbon/ceramic/NBR
- Special mechanical seal are available on demand

### TECHNICAL DATA

- Asincronous 2 poles motor
- Insulation class F
- Protection degree IP55
- 1~230V ± 10% 50Hz, 3~230/400V ± 10% 50Hz
- Permanent split capacitor and automatic thermal overload protection for single-phase version
- Thermal protection to be provided by the user for three-phase version
- DNA 2<sup>1</sup>/<sub>2</sub>" for DWO 300-400
- DNA 2" for the other models
- DNM 2"

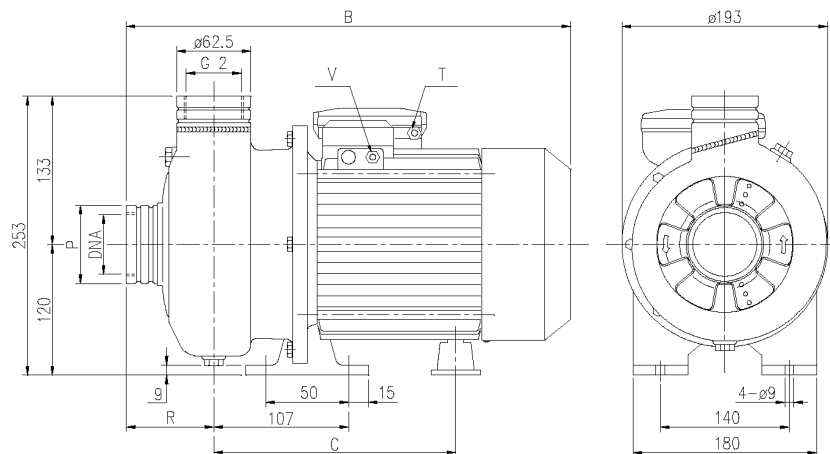

### DIMENSIONAL TABLE

Pump type		Dimensions (mm)							Weight	
		B	C	R	Ø P	V	T	Ø DNA	kg	
Single-phase	Three-phase					3~	1~		1~	3~
DWO 150 M	DWO 150	364	198,5	74	62,5	PG11	PG13,5	G 2		12,6
DWO 200 M	DWO 200	364	198,5	74	62,5	PG11	PG13,5	G 2	15,7	14,4
-	DWO 300	390	215,5	78	80	PG13,5	-	G 2 <sup>1</sup> / <sub>2</sub>		16,9
-	DWO 400	415	240,5	78	80	PG13,5	-	G 2 <sup>1</sup> / <sub>2</sub>		20,0

**PERFORMANCE CURVES** (according to ISO 9906 Annex A)

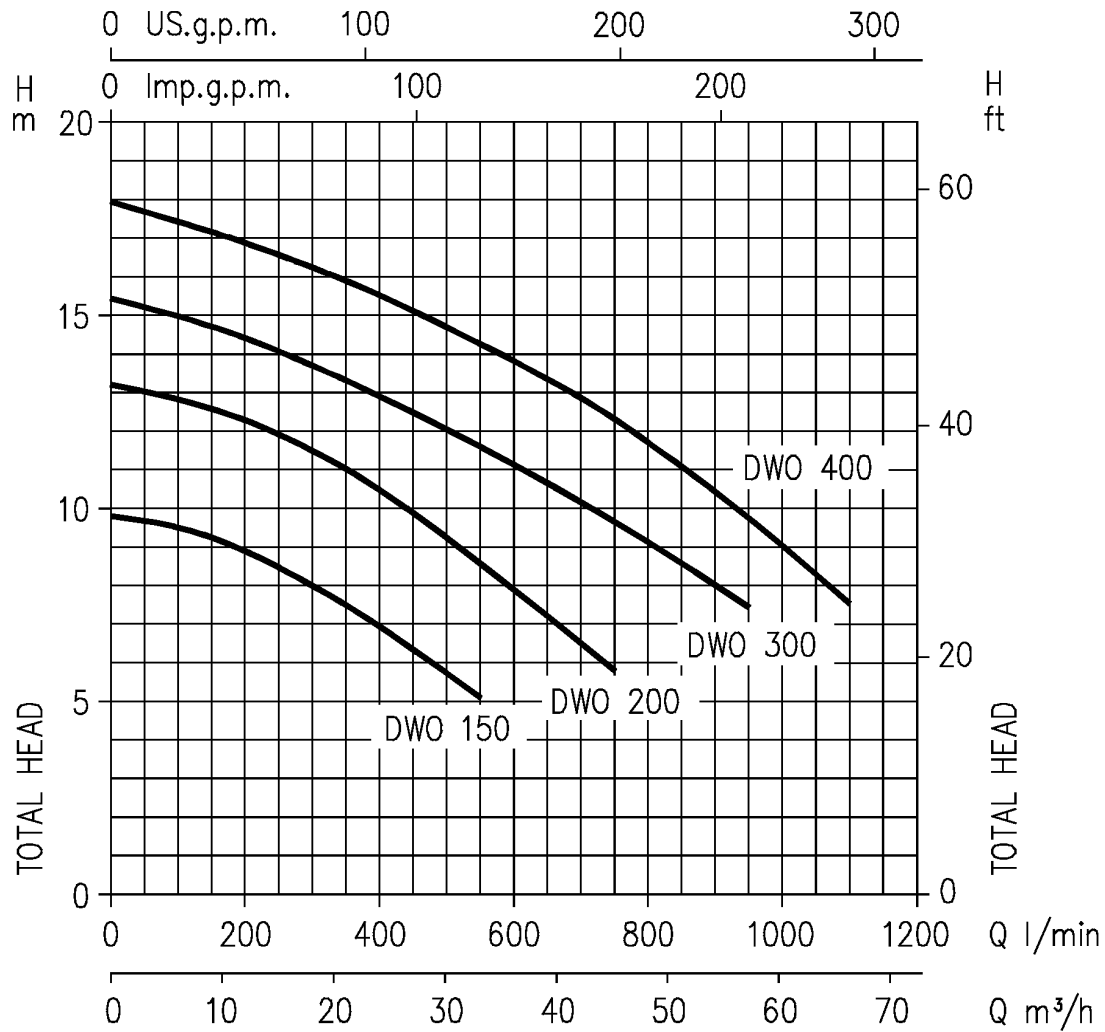

**PERFORMANCE TABLE**

Pump type		kW	Capacitor		Absorbed Current (A)			l/min m³/h	Q=Capacity							
Single-phase 230V 50Hz	Three-phase 230/400V 50Hz		μF	V <sub>c</sub>	Single-phase	Three-phase 230V 400V			100	200	300	400	550	750	950	1100
								H=Total head								
DWO 150 M	DWO 150	1.1	31,5	450	6,8	4,4	2,5	9,5	8,9	7,9	6,9	5,1	-	-	-	
DWO 200 M	DWO 200	1,5	40	450	9,0	6,1	3,5	12,7	12,3	11,5	10,5	8,6	5,8	-	-	
-	DWO 300	2,2	-	-	-	8,3	4,8	15	14,5	13,8	12,9	11,7	9,7	7,5	-	
-	DWO 400	3,0	-	-	-	11,0	6,4	17,5	16,9	16,3	15,6	14,3	12,4	9,8	7,6	