

Submersible sewage pumps made of cast iron, suitable for sewage and dirty water systems with solids, waste water, removal of treated liquid waste and tank emptying and general dirty water duties. (Kit discharge connector on request)



SPECIFICATIONS

- Maximum water temperature: 40°C
- Maximum passage of solids: 76 mm

MATERIALS

- Pump casing, impeller and elbow: cast iron
- Shaft in AISI 403
- Mechanical seal:
 - SiC/SiC/NBR (pump side)
 - Carbon/Ceramic/NBR (motor side)

TECHNICAL DATA

- 4 poles motor
- Insulation class F
- protection degree IP68
- 3~ 400V, 50 Hz
- DN80, DN100, DN150 flanges
- Power up to 22 kW

PERFORMANCE CURVES 80DML (according to ISO 9906 Annex A)

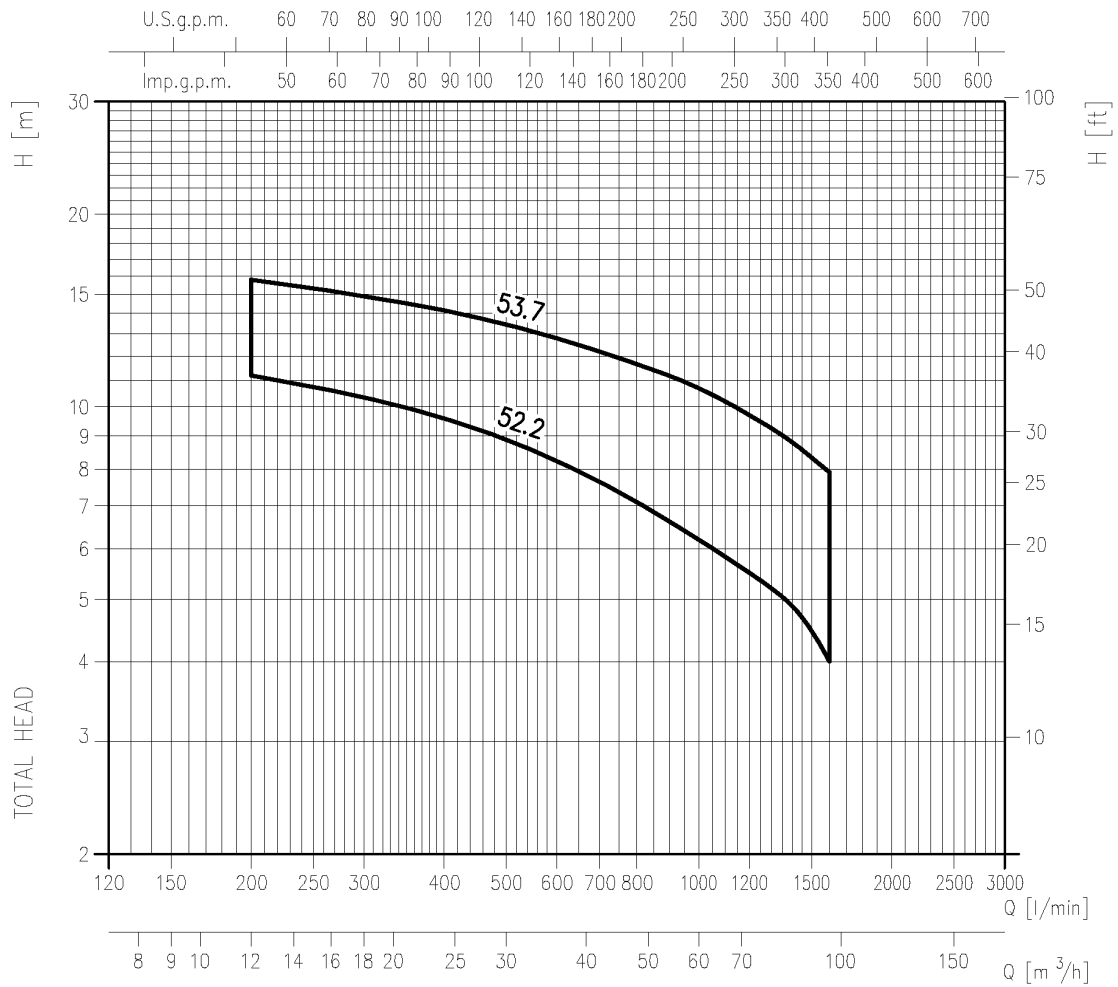

Pump type DML	kW	HP	Q=Capacity											
			l/min m³/h	0	200	400	600	800	1000	1200	1400	1600		
				H=total head [m]										
80DML52.2	2.2	3		13.1	11.2	9.6	8.2	7.1	6.2	5.5	4.9	4		
80DML53.7	3.7	5		17.9	15.8	14.2	12.8	11.7	10.7	9.7	8.8	7.9		

PERFORMANCE CURVES 100DML (according to ISO 9906 Annex A)

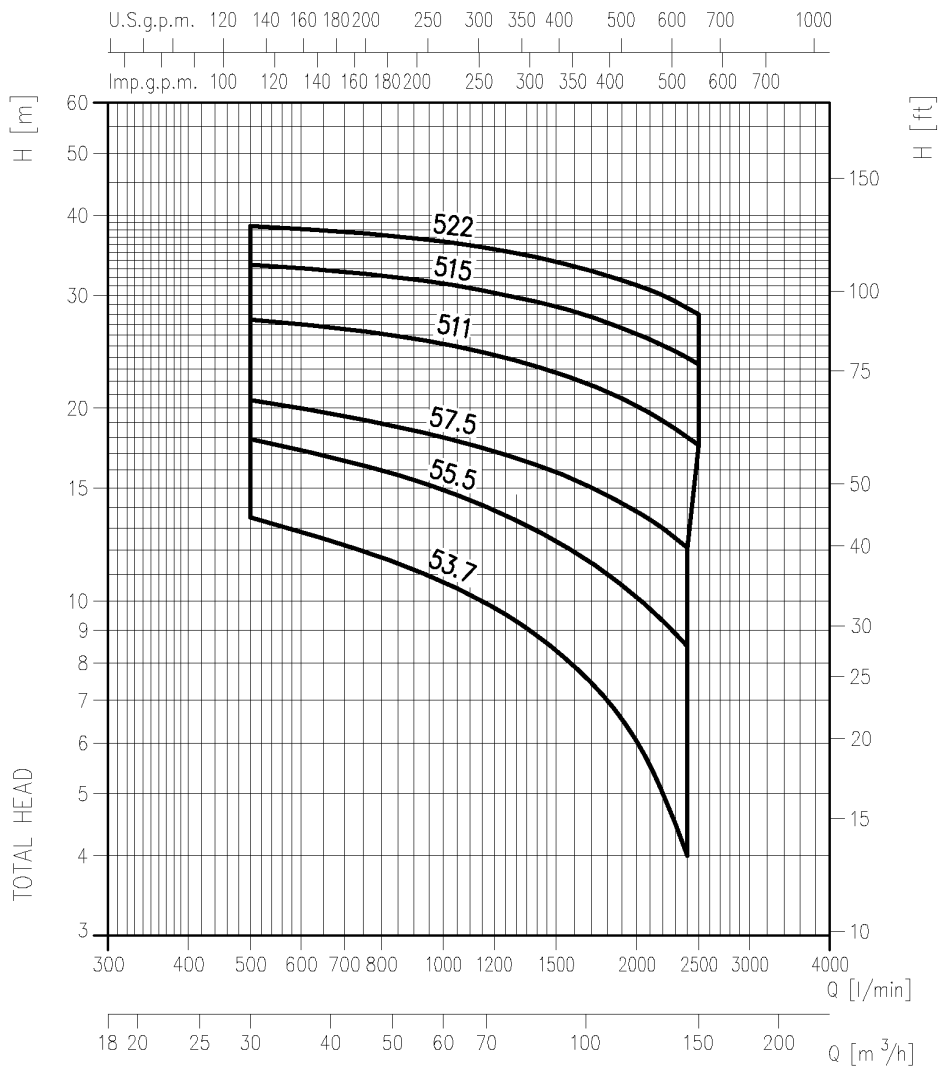

Pump type DML	kW	HP	Q=Capacity									
			l/min m³/h	0	500	1000	1300	1600	1900	2200	2400	2500
			H=total head [m]									
100DML53.7	3.7	5	17.9	13.5	10.7	9.3	7.9	6.5	5	4	-	
100DML55.5	5.5	7.5	22	17.9	14.9	13.4	11.9	10.6	9.3	8.5	-	
100DML57.5	7.5	10	25.3	20.6	18	16.7	15.5	14.2	13	12.1	-	
100DML511	11	15	30.3	27.5	25.2	23.7	22.2	20.7	19.1	18	17.5	
100DML515	15	20	35	33.5	31.3	29.8	28.3	26.7	25.1	24	23.4	
100DML522	22	30	40	38.5	36.4	34.9	33.3	31.7	30	28.7	28	

PERFORMANCE CURVES 150DML (according to ISO 9906 Annex A)

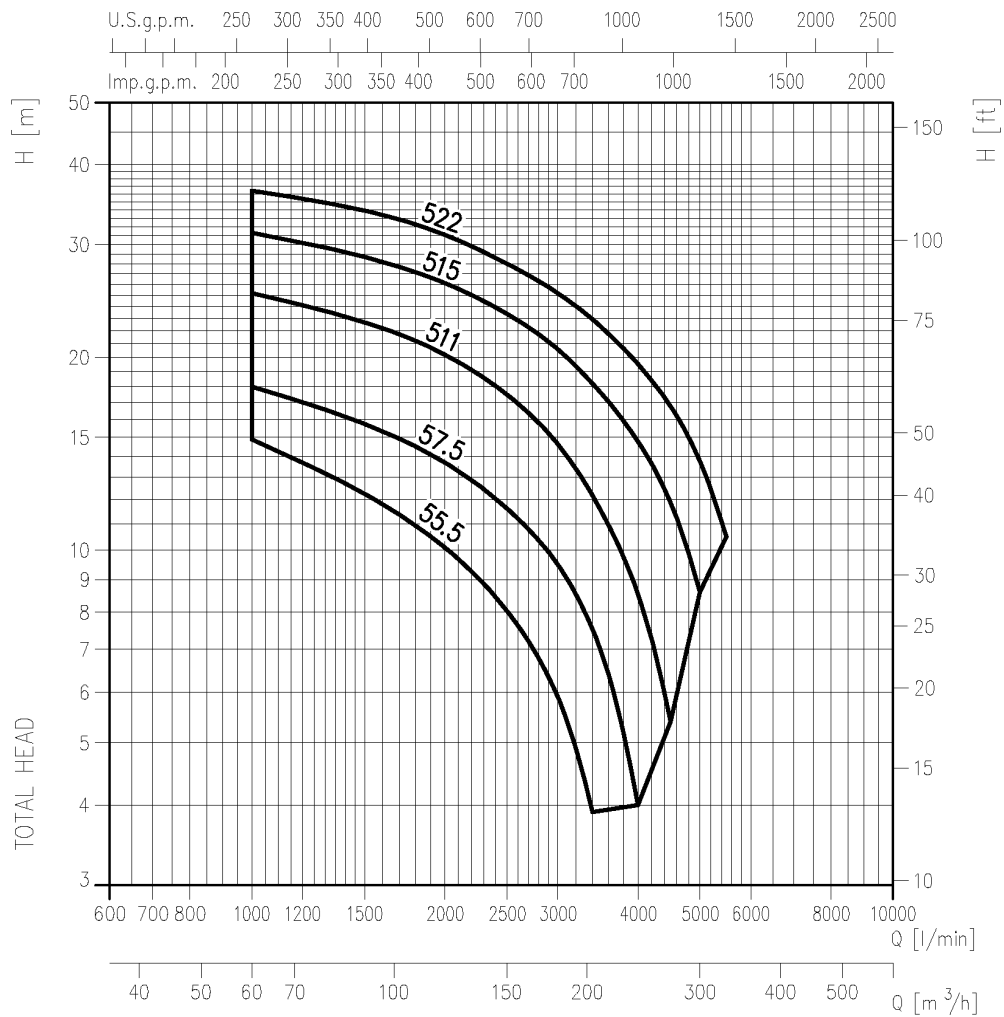

Pump type DML	kW	HP	Q=Capacity									
			l/min m³/h	0	1000	2000	2500	3000	3400	4000	4500	5000
			H=Total head [m]									
150DML55.5	5.5	7.5	22	14.9	10.1	8	5.9	3.9	-	-	-	-
150DML57.5	7.5	10	25.3	18	13.7	11.6	9.5	7.5	4	-	-	-
150DML511	11	15	30.3	25.2	20.2	17.5	14.7	12.2	8.6	5.4	-	-
150DML515	15	20	35	31.3	26.1	23.4	20.6	18.2	14.8	11.9	8.6	-
150DML522	22	30	40	36.4	31.1	28	25.2	22.9	19.5	16.8	13.8	10.5

DIMENSIONS

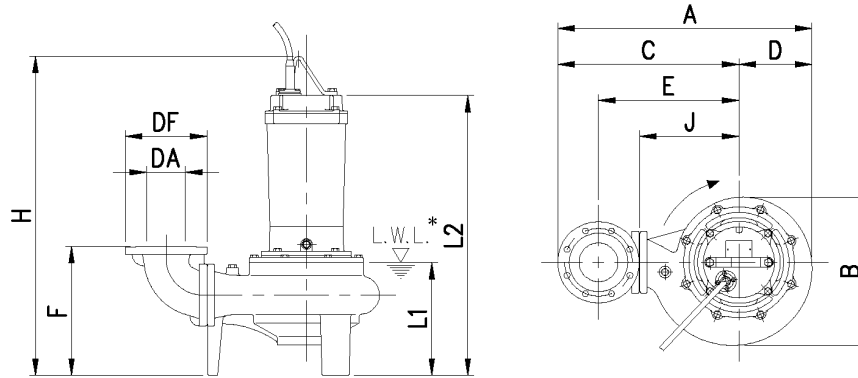

* LWL = Low water level

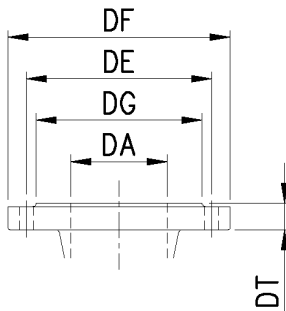

FLANGES

DA	DG	DE	DF	DT
80	138	160	200	22
100	158	180	220	24
150	212	240	285	26

DIMENSIONAL TABLE

Pump type DML	Dimensions												Weight kg
	DA	kW	A	B	C	D	E	F	H	J	L1	L2	
80DML52.5	80	2.2	542	320	385	157	285	308	668	210	279	547	80
80DML53.7	80	3.7	542	320	385	157	285	308	727	210	279	627	87
100DML53.7	100	3.7	582	320	425	157	315	313	727	210	279	627	89
100DML55.5	100	5.5	658	381	470	188	360	339	824	255	310	724	121
100DML57.5	100	7.5	658	381	470	188	360	339	824	255	310	724	125
100DML511	100	11	751	455	530	221	420	355	938	315	329	778	160
100DML515	100	15	751	455	530	221	420	355	938	315	329	778	166
100DML522	100	22	795	497	550	245	440	358	1021	335	342	841	226
150DML55.5	150	5.5	715.5	381	527.5	188	385	369	824	255	310	724	127
150DML57.5	150	7.5	715.5	381	527.5	188	385	369	824	255	310	724	132
150DML511	150	11	808.5	455	587.5	221	445	385	938	315	329	778	166
150DML515	150	15	808.5	455	587.5	221	445	385	938	315	329	778	172
150DML522	150	22	852.5	497	607.5	245	465	388	1021	335	342	841	232

KIT DISCHARGE CONNECTOR DIMENSIONS LM80

80 (100) DML 52.2, 53.7

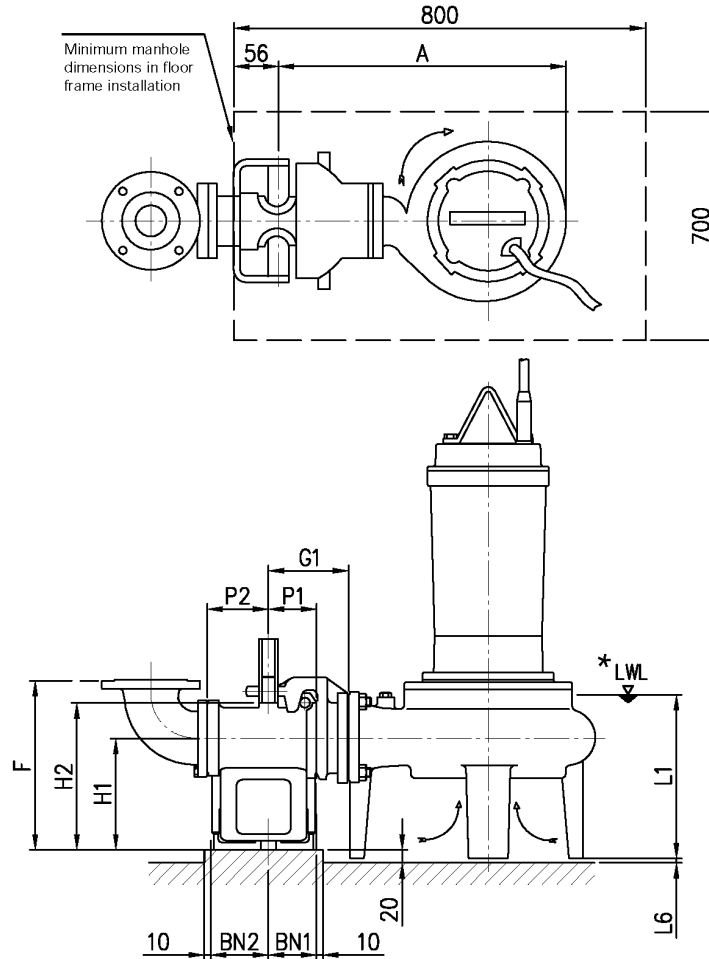

* LWL = Low water level

FLANGES

DA	DG	DE	DF	DT
80	138	160	200	22
100	158	180	220	24

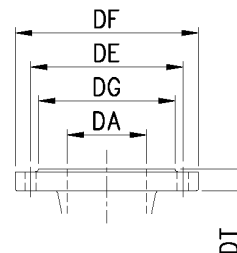

DIMENSIONAL TABLE

Pump type DML	Dimensions													Kit discharge connector	Weight kg	
	A	P1	P2	G1	G2	F	H1	H2	L1	L6	BN1	BN2	D1			E1
80DML52.2	492	75	90	125	165	295	175	230	279	7	75	90	15	155	LM80	17
80DML53.7	492	75	90	125	165	295	175	230	279	7	75	90	15	155	LM80	17
100DML53.7	492	75	90	125	195	300	175	230	279	7	75	90	15	155	LM80	17

KIT DISCHARGE CONNECTOR DIMENSIONS LL100

100 (150) DML

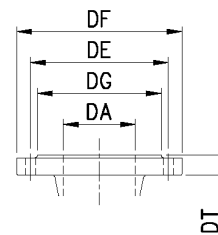
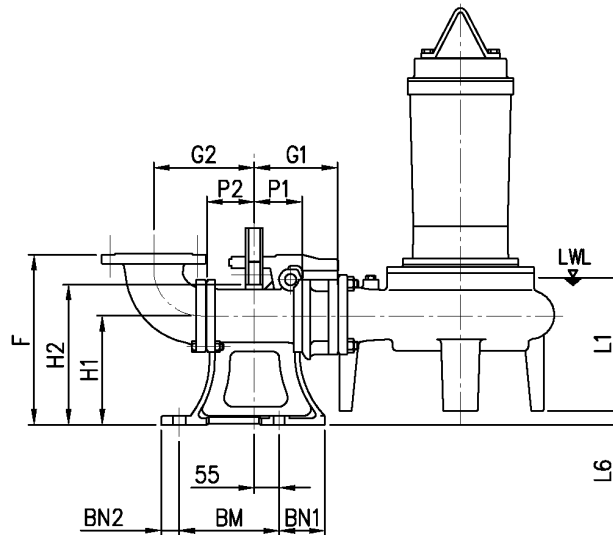
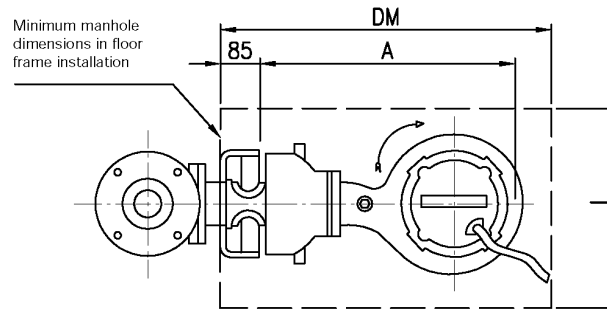

FLANGES

DA	DG	DE	DF	DT
100	158	180	220	24
150	212	240	285	26

DIMENSIONAL TABLE

Pump type DML	Dimensions																	Kit discharge connector	Weight kg
	A	P1	P2	G1	G2	F	H1	H2	L1	L6	BN1	BN2	BM	DM	I	D1	E1		
100DML55.5	628	105	105	185	210	370	240	265	310	31	100	40	220	800	700	19	175	LL100	46
100DML57.5	628	105	105	185	210	370	240	265	310	31	100	40	220	800	700	19	175	LL100	46
100DML511	721	105	105	185	210	370	240	265	329	15	100	40	220	1000	700	19	175	LL100	46
100DML515	721	105	105	185	210	370	240	265	329	15	100	40	220	1000	700	19	175	LL100	46
100DML522	765	105	105	185	210	370	240	265	342	12	100	40	220	1000	700	19	175	LL100	46
150DML55.5	628	105	105	185	235	400	240	265	310	31	100	40	220	800	700	19	175	LL100	46
150DML57.5	628	105	105	185	235	400	240	265	310	31	100	40	220	800	700	19	175	LL100	46
150DML511	721	105	105	185	235	400	240	265	329	15	100	40	220	1000	700	19	175	LL100	46
150DML515	721	105	105	185	235	400	240	265	329	15	100	40	220	1000	700	19	175	LL100	46
150DML522	765	105	105	185	235	400	240	265	342	12	100	40	220	1000	700	19	175	LL100	46