

Horizontal centrifugal multistage pumps suitable for pressure boosting systems, car washing, small garden irrigation and general clean water pumping.



SPECIFICATIONS

- Maximum working pressure: 10 bar
- Maximum liquid temperature:
35°C according EN 60335-2-41 for domestic uses
40°C for other uses

MATERIALS

- Pump body and bracket in cast iron
- External casing in AISI 304
- Impeller and diffuser in tecnopolymer
- Shaft in AISI 416
- Mechanical seal in carbon/ceramic/NBR

TECHNICAL DATA

- Asincronous 2 poles motor
- Insulation class F
- Protection degree IP44
- 1~230V ± 10% 50Hz, 3~230/400V ± 10% 50Hz
- Permanent split capacitor and automatic thermal overload protection for single-phase version
- Thermal protection to be provided by the user for three-phase version
- DNM 1" – DNA 1^{3/4}" for COMPACT B/12 and B/15, 1" for other models

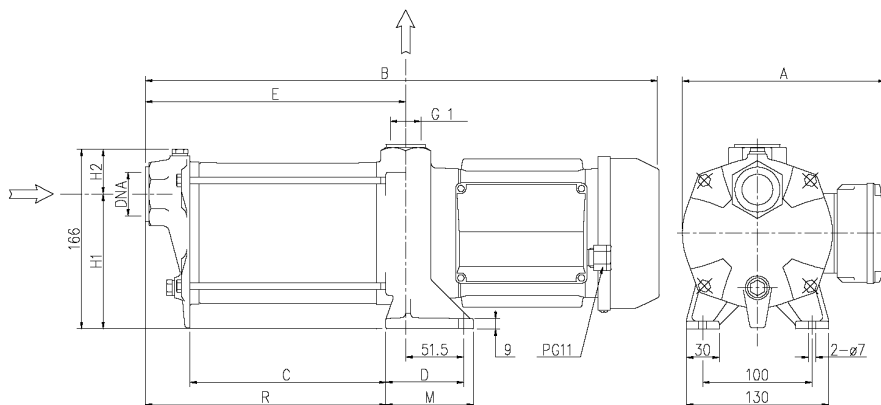

COMPACT

DIMENSIONAL TABLE

Pump type		Dimensions (mm)										Weight kg		
		A	B	C	D	E	H1	H2	M	R	DNA			
Single-phase	Three-phase	1~	3~											
COMPACT AM/4	COMPACT A/4	183.5	159	307.5	82	51.5	120.5	127.5	38.5	62	120.5	G1	8.4	
COMPACT AM/6	COMPACT A/6	183.5	159	333.5	108	51.5	146.5	127.5	38.5	62	146.5	G1	9.3	
COMPACT AM/8	COMPACT A/8	183.5	159	359.5	134	51.5	172.5	127.5	38.5	62	172.5	G1	10.3	
COMPACT AM/10	COMPACT A/10	193.5	169	426	142	69.5	198.5	123.5	42.5	80	180.5	G1	14.5	
COMPACT AM/12	COMPACT A/12	193.5	169	452	168	69.5	224.5	123.5	42.5	80	206.5	G1	15.5	
COMPACT AM/15	COMPACT A/15	193.5	169	490	194	69.5	250.5	123.5	42.5	80	232.5	G1	16.7	
COMPACT BM/12	COMPACT B/12	193.5	169	400	116	69.5	172.5	123.5	42.5	80	154.5	G1 1/4	14.9	
COMPACT BM/15	COMPACT B/15	193.5	169	438	142	69.5	198.5	123.5	42.5	80	180.5	G1 1/4	15.9	

PERFORMANCE CURVES (according to ISO 9906 Annex A)

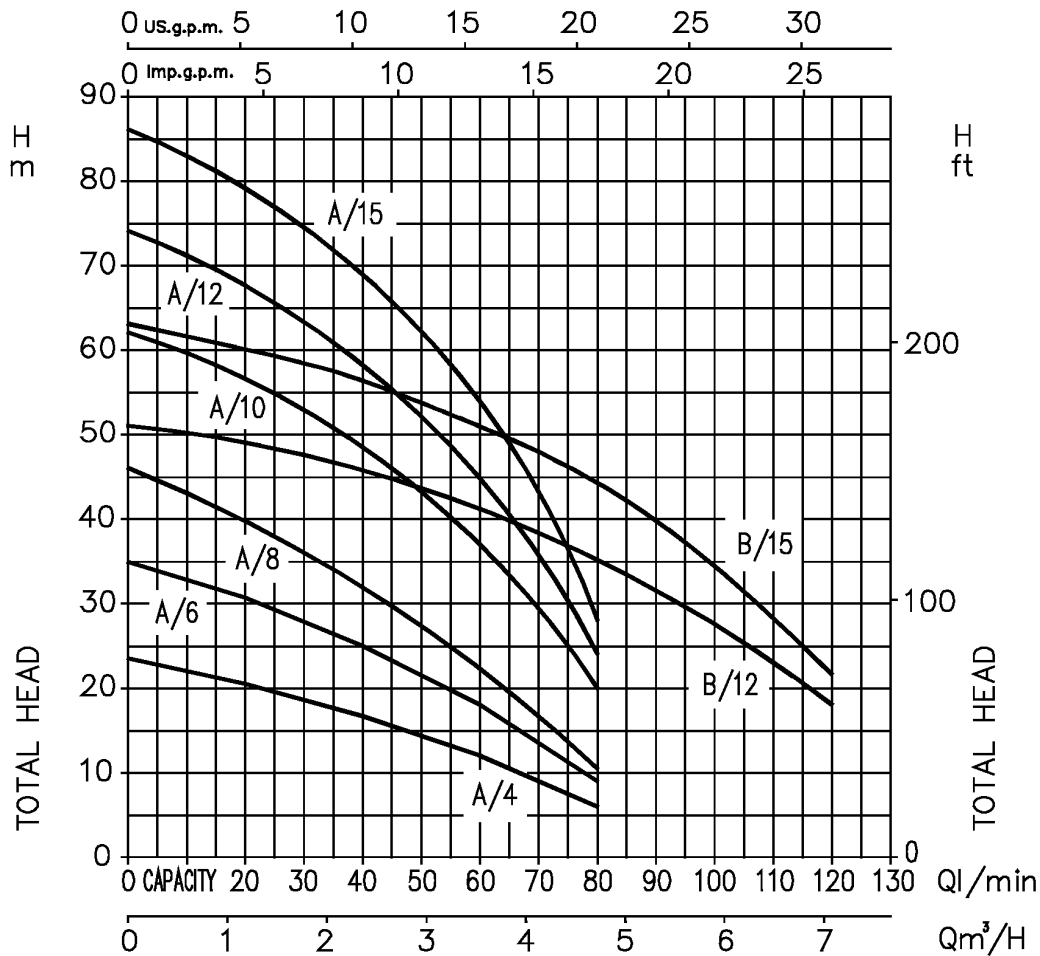

PERFORMANCE TABLE

Pump type		kW	Capacitor		Absorbed Current (A)			l/min m³/h	Q=Capacity							
Single-phase 230V 50Hz	Three-phase 230/400V 50Hz		µF	V _c	Single-phase	Three-phase 230V	400V		20	30	40	50	60	80	100	120
									1,2	1,8	2,4	3	3,6	4,8	6	7,2
									H=Total head							
COMPACT AM/4	COMPACT A/4	0,3	10	450	2,5	1,9	1,1	21	18,7	16,7	14,4	11,9	6	-	-	-
COMPACT AM/6	COMPACT A/6	0,44	12,5	450	3,0	2,3	1,3	31	28,2	25,2	21,8	18	9	-	-	-
COMPACT AM/8	COMPACT A/8	0,6	14	450	4,0	2,6	1,5	40	36,1	32	27,4	22,4	10,5	-	-	-
COMPACT AM/10	COMPACT A/10	0,75	20	450	6,0	4,2	2,4	57	53	48,6	43,4	37,1	20	-	-	-
COMPACT AM/12	COMPACT A/12	0,9	31,5	450	6,2	4,7	2,4	68	63,4	58,4	52,3	44,9	24	-	-	-
COMPACT AM/15	COMPACT A/15	1,1	31,5	450	7,3	5,7	3,3	79	74,6	69,1	62,3	54	28	-	-	-
COMPACT BM/12	COMPACT B/12	0,9	31,5	450	5,8	4,7	2,7	-	47,5	45,9	43,7	41,3	35,2	27,6	18	-
COMPACT BM/15	COMPACT B/15	1,1	31,5	450	7,3	5,9	3,4	-	58	56	54	51,5	44,5	34,5	22	-