

CENTRIFUGAL PUMPS - TWIN IMPELLER in cast iron

Twin impeller centrifugal pumps with hydraulic parts manufactured from cast iron, suitable for irrigation and non-aggressive liquids for civil and industrial uses.



SPECIFICATIONS

- Maximum working pressure: 6 bar for CDA 0.75-1.00
10 bar for other models
- Maximum liquid temperature:
35°C according EN 60335-2-41 for domestic uses
40°C for CDA 0.75-1.00
90°C for other models

MATERIALS

- Pump body in cast iron
- Mechanical seal in carbon/ceramic/NBR
- Impeller: - in tecnopolymer for CDA 0.75-1.00
- in brass for the other models
- Shaft: - in AISI 303 for CDA 1.50-2.00-3.00
- in AISI 304 for CDA 4.00-5.50
- in AISI 416 for the other models
- Bracket: - in alluminium for CDA 0.75-1.00
- in cast iron for the other models
- Casing cover: - in AISI 304 for CDA 0.75-1.00
- in cast iron for the other models

TECHNICAL DATA

- T.E.F.C. 2 poles motor
- Insulation class F
- Protection degree IP44
- 1~230V \pm 10% 50Hz, 3~230/400V \pm 10% 50Hz
- Permanent split capacitor and automatic thermal overload protection for single-phase version
- Thermal protection to be provided by the user for three-phase version

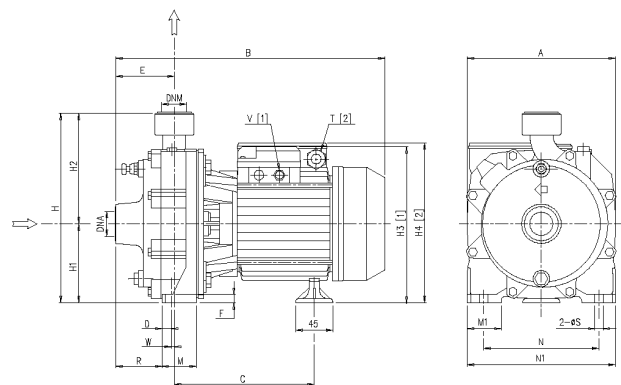

DIMENSIONAL TABLE

Pump type		Dimensions (mm)																				Weight		
Single-phase	Three-phase	A	B	C	D	E	F	H	H1	H2	H3	H4	M	M1	N	N1	R	T	V	W	S	DNA	DNM	kg
CDA 0.75 M	CDA 0.75 T	183	336,3	179,8	8,3	73	9	227	97	130	197,5	198	42	40	140	180	57,5	PG11	PG11	6,8	9,5	G 1	G 1	13,5
CDA 1.00 M	CDA 1.00 T	183	336,3	179,8	8,3	73	9	227	97	130	197,5	198	42	40	140	180	57,5	PG11	PG11	6,8	9,5	G 1	G 1	15,0
CDA 1.50 M	CDA 1.50 T	209	394,8	218,3	8,3	86	9	265	110	155	224	242	48	40	155	195	65,5	PG13,5	PG11	12,3	9,5	G 1 1/4	G 1	25,0
CDA 2.00 M	CDA 2.00 T	209	410,8	218,3	8,3	86	9	265	110	155	224	242	48	40	155	195	65,5	PG13,5	PG11	12,3	9,5	G 1 1/4	G 1	27,0
-	CDA 3.00 T	194	410,8	218,3	8,3	86	9	265	110	155	224	-	48	40	155	195	65,5	-	PG11	12,3	9,5	G 1 1/4	G 1	27,0
-	CDA 4.00 T	228	467,3	225,3	12	95,5	12	308,5	133,5	175	264,5	-	57	50	180	230	71,5	-	G 1 1/2	12	12	G 1 1/2	G 1 1/4	42,5
-	CDA 5.50 T	228	467,3	225,3	12	95,5	12	308,5	133,5	175	264,5	-	57	50	180	230	71,5	-	G 1 1/2	12	12	G 1 1/2	G 1 1/4	46,3

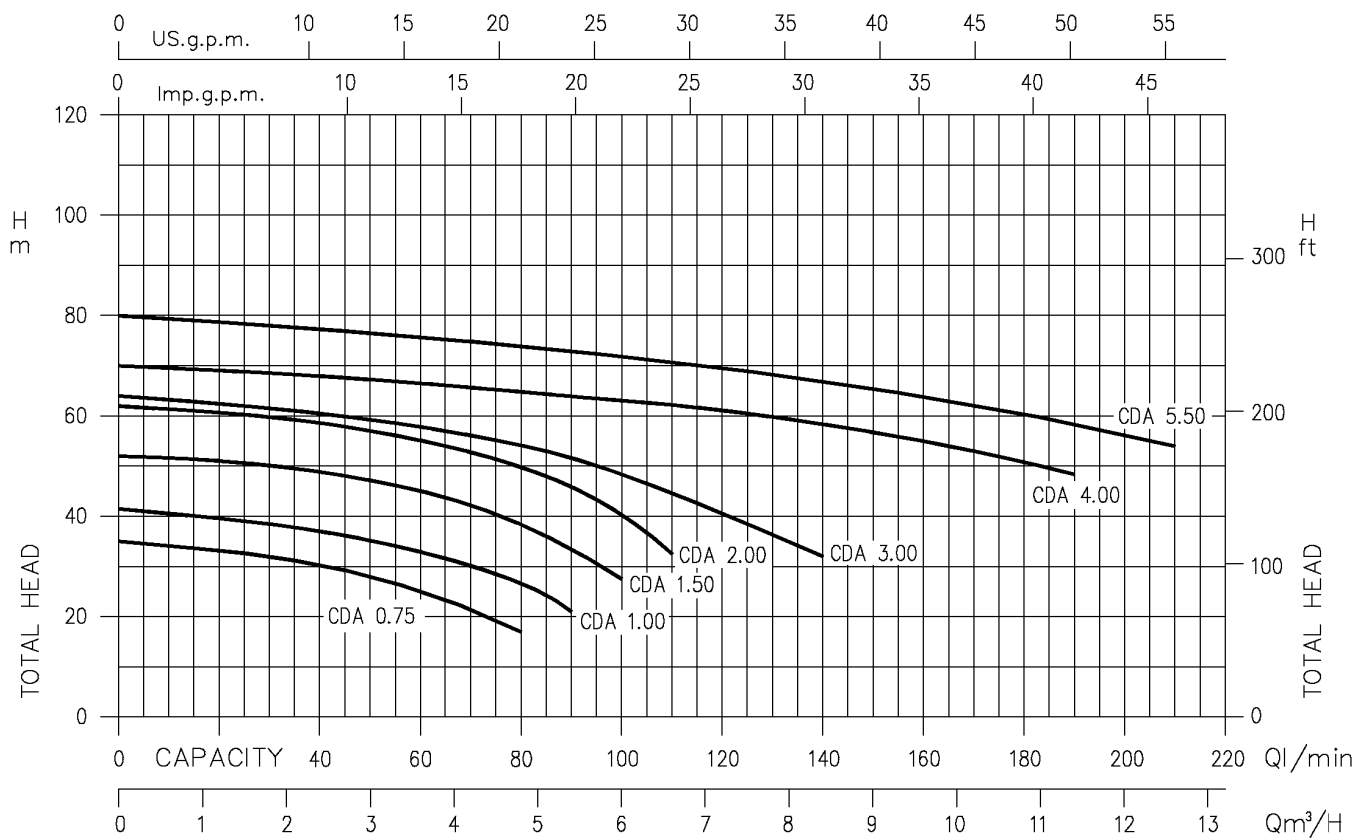
PERFORMANCE CURVES (according to ISO 9906 Annex A)

PERFORMANCE TABLE

Pump type		kW	Capacitor		Absorbed Current (A)			l/min m ³ /h	Q=Capacity										
Single-phase 230V 50Hz	Three-phase 230/400V 50Hz		μF	V _c	Single-phase	Three-phase 230V 400V			20	40	50	80	90	100	110	140	170	190	210
CDA 0.75 M	CDA 0.75 T	0,55	16	450	5,0	3,4	2,0	33	30,2	27,9	17	-	-	-	-	-	-	-	
CDA 1.00 M	CDA 1.00 T	0,75	20	450	6,1	4,0	2,3	39,5	37	35,2	27	21	-	-	-	-	-	-	
CDA 1.50 M	CDA 1.50 T	1,1	35	450	8,6	5,6	3,3	50,8	48,8	47,1	38,4	33,4	27,5	-	-	-	-	-	
CDA 2.00 M	CDA 2.00 T	1,5	40	450	10,8	7,2	4,1	60,5	58,6	56,9	49,8	46,5	40,3	32,5	-	-	-	-	
-	CDA 3.00 T	2,2	-	-	-	8,8	5,1	-	60,5	59,3	54,1	51,6	48,4	44,6	32	-	-	-	
-	CDA 4.00 T	3,0	-	-	-	13,0	7,5	-	-	67	64,8	63,9	62,5	62	58	53,5	48	-	
-	CDA 5.50 T	4,0	-	-	-	16,5	9,5	-	-	-	76,5	73,9	72,9	71,8	70,5	66,8	62	58,3	