

Twin impeller centrifugal pumps with hydraulic components constructed in stainless steel AISI 304, suitable for pressure boosting, water supply, water treatment & irrigation. Air conditioning systems and general water pumping including moderately aggressive liquids



SPECIFICATIONS

- Maximum working pressure: 8 bar
- Maximum liquid temperature:
35°C according EN 60335-2-41 for domestic uses
60°C for other uses
110° for H version

MATERIALS

- Pump body, impeller, diffuser and casing cover in AISI 304
- Shaft in AISI 304
- Bracket and motor casing in aluminium
- Mechanical seal in carbon/ceramic/NBR
- Special mechanical seal are available on demand

TECHNICAL DATA

- T.E.F.C. 2 poles motor
- Insulation class F
- Protection degree IP55
- 1 230V ± 10% 50Hz, 3 230/400V ±10% 50Hz
- Permanent split capacitor and automatic thermal overload protection for single-phase version
- Thermal protection to be provided by the user for three-phase version
- DNA 1^{1/2}" for 2CDX200
DNA 1^{1/4}" for the other models
- DNM 1"

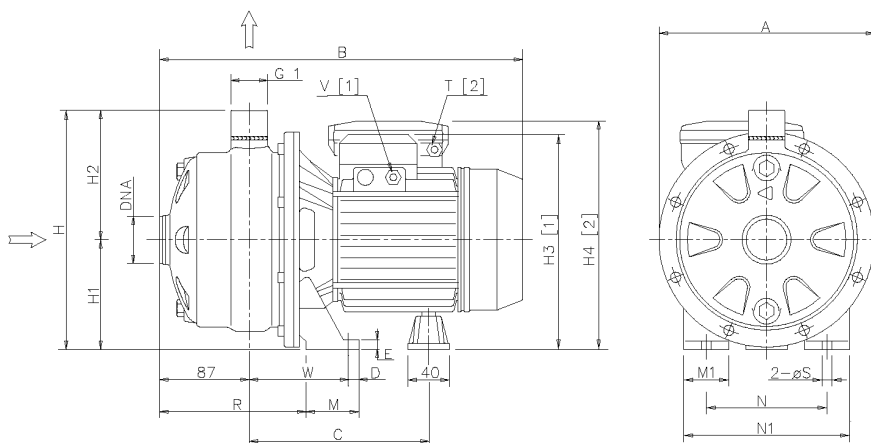

DIMENSIONAL TABLE

Pump type		Dimensions (mm)																		Weight kg			
Single-phase	Three-phase	A	B	C	D	E	H	H1	H2	H3	H4	M	M1	N	N1	R	T	V	W	S	DNA	Single-phase	Three-phase
2CDXM 70/10	2CDX 70/10	208	355	182	12,5	8	229	106	123	209	215	50	38	120	160	142,5	PG11	PG11	93	9	G 1 1/4	13,5	13,3
2CDXM 70/12	2CDX 70/12	208	355	182	12,5	8	229	106	123	209	215	50	38	120	160	142,5	PG11	PG11	93	9	G 1 1/4	14,2	13,8
2CDXM 70/15	2CDX 70/15	232	380	199	12,5	8	250	118	132	235	249	55	40	140	180	140	PG13,5	PG11	95,5	9	G 1 1/4	17,4	16,4
2CDXM 70/20	2CDX 70/20	232	385	199	12,5	8	250	118	132	235	249	55	40	140	180	140	PG13,5	PG11	95,5	9	G 1 1/4	18,6	18,2
2CDXM 120/15	2CDX 120/15	208	380	199	12,5	8	229	106	123	223	237	55	40	140	180	140	PG13,5	PG11	95,5	9	G 1 1/4	15,5	15,3
2CDXM 120/20	2CDX 120/20	208	380	199	12,5	8	229	106	123	223	237	55	40	140	180	140	PG13,5	PG11	95,5	9	G 1 1/4	18,0	16,9
-	2CDX 120/30	232	390	209,5	12,5	8	250	118	132	240	-	65	40	140	180	145	-	PG13,5	110,5	9	G 1 1/4	-	23,2
-	2CDX 120/40	232	420	231,5	12,5	8	250	118	132	240	-	65	40	140	180	145	-	PG13,5	110,5	9	G 1 1/4	-	26,4
-	2CDX 200/30	208	394	210	12,5	8	229	106	123	240	-	65	40	140	180	145	-	PG13,5	110,5	9	G 1 1/2	-	25,0
-	2CDX 200/40	232	420	231,5	12,5	8	250	118	132	240	-	65	40	140	180	145	-	PG13,5	110,5	9	G 1 1/2	-	25,0
-	2CDX 200/50	232	445	231,5	16,0	13	250	118	132	252	-	68	50	160	210	145	-	PG16	110,0	12	G 1 1/2	-	32,7

PERFORMANCE CHART (according to ISO 9906 Annex A)

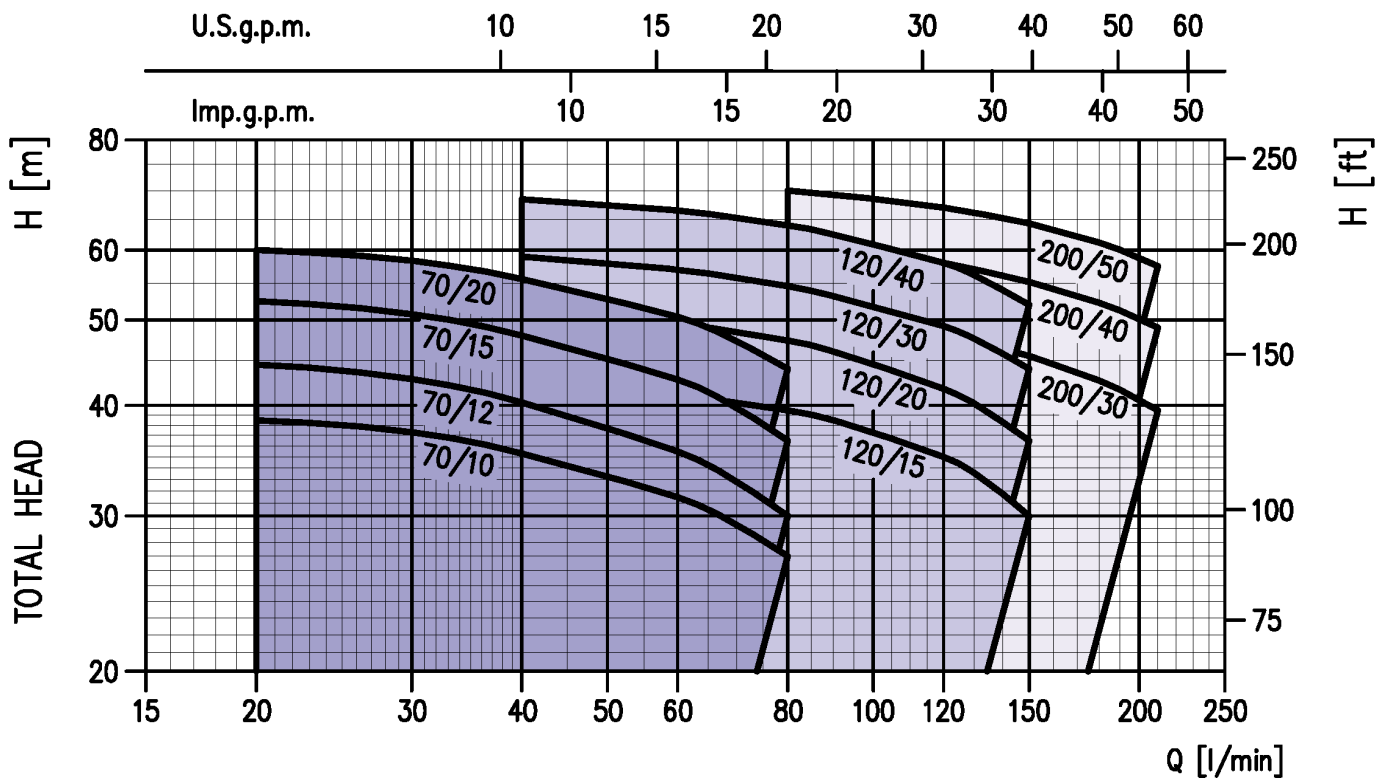

PERFORMANCE TABLE

Pump type		kW	Capacitor		Absorbed Current (A)			l/min m ³ /h	Q=Capacity							
Single-phase 230V 50Hz	Three-phase 230/400V 50Hz		μF	V _c	Single-phase	Three-phase 230V 400V			20	40	60	H=Total head		150	180	210
								1,2	2,4	3,6	4,8	7,2	9	10,8	12,6	
2CDXM 70/10	2CDX 70/10	0,75	20	450	6,0	4,0	2,3	38,5	35,3	31,5	27	-	-	-	-	
2CDXM 70/12	2CDX 70/12	0,9	31,5	450	7,0	5,0	2,9	44,5	40,3	35,5	30	-	-	-	-	
2CDXM 70/15	2CDX 70/15	1,1	35	450	8,0	5,6	3,2	52,5	48	42,8	36,5	-	-	-	-	
2CDXM 70/20	2CDX 70/20	1,5	40	450	9,9	7,0	4,0	60	55,6	50,4	44	-	-	-	-	
2CDXM 120/15	2CDX 120/15	1,1	35	450	8,3	5,6	3,2	-	42	41	39,5	35	30	-	-	
2CDXM 120/20	2CDX 120/20	1,5	40	450	10,2	7,0	4,0	-	51,5	49,5	47,4	41,8	36,5	-	-	
-	2CDX 120/30	2,2	-	-	-	8,7	5,0	-	59	57	54,6	49,2	44	-	-	
-	2CDX 120/40	3,0	-	-	-	10,8	6,2	-	68,5	66,5	64	58	52	-	-	
-	2CDX 200/30	2,2	-	-	-	10,4	6,0	-	-	52	50,8	48,1	45,5	42,7	39,5	
-	2CDX 200/40	3,0	-	-	-	11,4	6,6	-	-	62,5	61,1	58	55,2	52,3	49	
-	2CDX 200/50	3,7	-	-	-	15	8,7	-	-	71,5	70,1	67	64,3	61,2	57,5	

PERFORMANCE CURVES series 2CDX 70 (according to ISO 9906 Annex A)

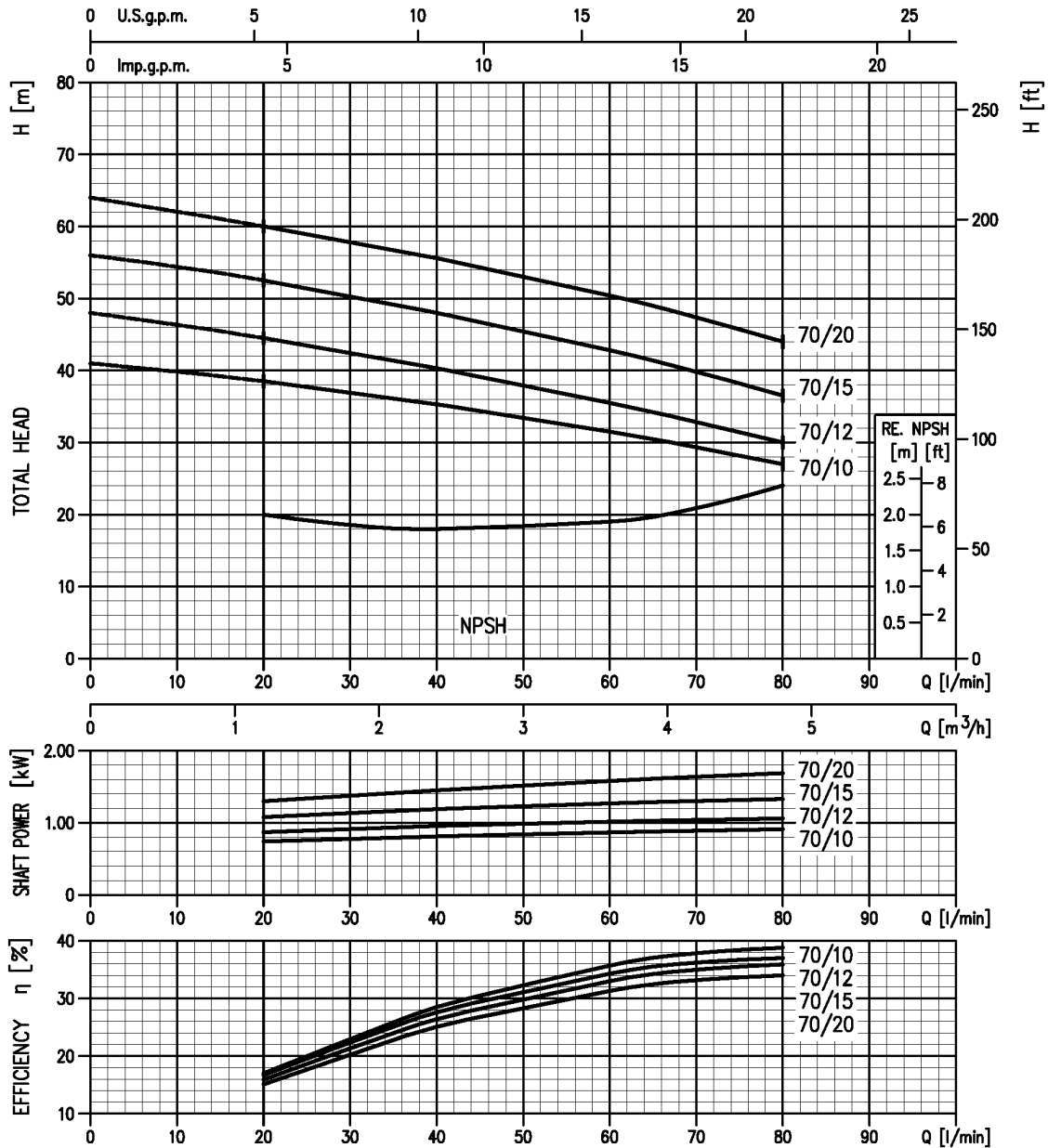

PERFORMANCE CURVES 2CDX 120 series (according to ISO 9906 Annex A)

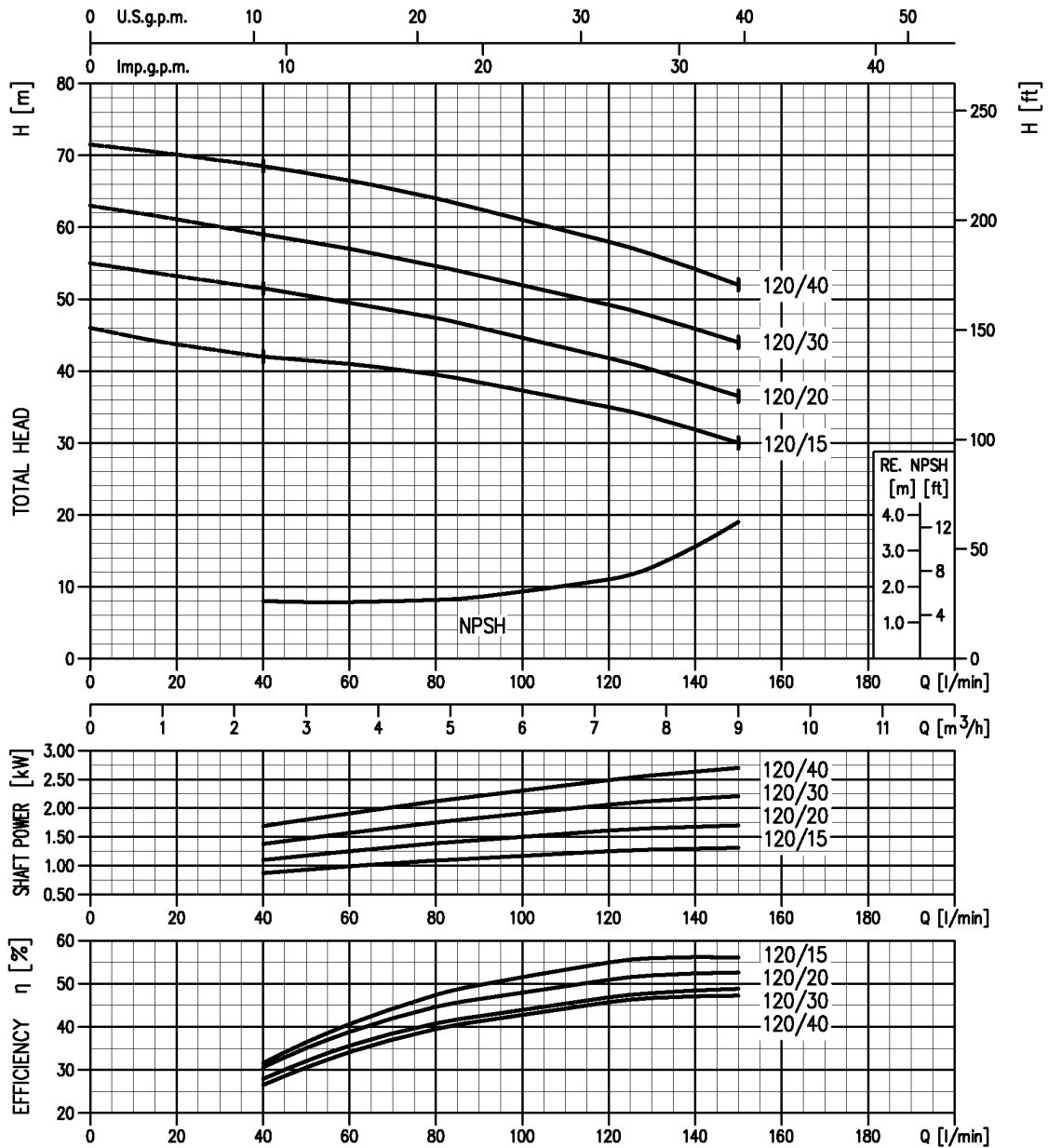

PERFORMANCE CURVES 2CDX 200 series (according to ISO 9906 Annex A)

